



OPERATOR'S MANUAL



REGISTER YOUR PRODUCT

<https://www.novuspowerequipment.com/product-registration>

MODEL: NV17DRTG

Product No: A040060001

17 in. REAR TINE TILLER

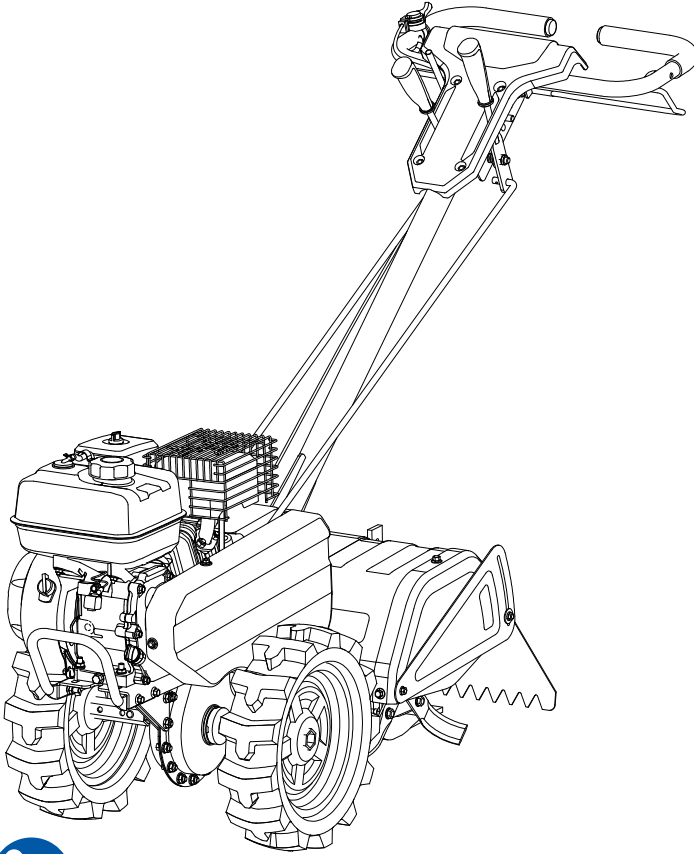

Have a product question or need technical support?

Contact Us:

- Website: www.novuspowerequipment.com
- Toll free: 1-800-409-7802 Mon-Fri 8-4 CST
- Email: support@novuspowerequipment.com



EN

Vol. 2026-01

CONTENTS

Specifications	3
Introduction / Register Your Product / Safety Definitions	4
Important Safety instructions	5
Know your product	10
Assembly	11
Operation	14
Maintenance	19
Transportation and Storage	24
Troubleshooting	25
Basic Service Parts List	26
Warranty Statement	27

SPECIFICATIONS

Tiller Specifications

Model	NV17DRTG
Tine Diameter (in.)	12
Tine Direction	Dual Rotation
Tilling Width (in.)	17
Tilling Depth (in.)	4
Wheel Diameter (in.)	14
Length (in.)	61.0
Width (in.)	19.7
Height (in.)	45.3
Weight (lbs.)	165
Speeds	1 Forward / 1 Neutral / 1 Reverse

Engine Specifications

Engine Model	W210F
Displacement	212cc
Type	4-Stroke, Air Cooled, Overhead Valve (OHV)
Fuel Capacity	0.63 Gallon
Fuel Type	Fresh, clean regular unleaded gasoline with a minimum octane rating of 87 and an ethanol content of no more than 10% by volume.
Oil Capacity	20 fl.oz (600 ml)
Oil Type	SAE 10W-30

INTRODUCTION

Congratulations on your purchase of a Novus branded product. This model is the result of Novus's vast experiences in the production of high-quality, cost-effective equipment.

It represents the high degree of reliability and innovation that Novus has dedicated itself to.

This manual will give you an understanding of the assembly, operation and basic maintenance of this unit. If you have any questions concerning the operation or maintenance, please contact us at support@novuspowerequipment.com or 800-409-7802.

We want you to continue to use and be satisfied with your NOVUS product for years to come, therefore please fully familiarize yourself, and others who plan on operating the product, with the proper safety and operation procedures before each use.

Novus Power Products LLC. continually seeks advancements in product design and quality. Therefore, while this manual contains the most current product information available at the time of printing, there may be minor discrepancies between your product and this manual.

When contacting us about parts and/or service, you will need to supply the complete product and serial number of your product.

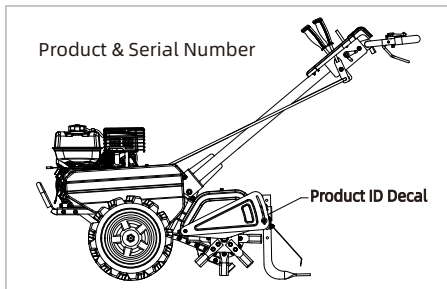

Product Number
SERIAL NUMBER
DATE OF PURCHASE

REGISTER YOUR PRODUCT

To ensure you receive important service information in the event of a product update or recall, please register your product. Your information will remain confidential. It will not be released to any other company or organization. Failure to register your product does not diminish your warranty rights.

SCAN QR CODE TO REGISTER



SAFETY DEFINITIONS

The purpose of safety symbols is to attract your attention to possible dangers. The safety symbols, and their explanations, deserve your careful attention and understanding. The safety warnings do not by themselves eliminate any danger. The instructions or warnings they give are not substitutes for proper accident prevention measures.

⚠ DANGER

DANGER indicates a hazardous situation which, if not avoided, will result in death or serious injury.

⚠ WARNING

WARNING indicates a hazardous situation which, if not avoided, could result in death or serious injury.

⚠ CAUTION

CAUTION indicates a hazardous situation which, if not avoided, could result in minor or moderate injury.

IMPORTANT SAFETY INSTRUCTIONS

⚠ DANGER

Engine exhaust contains carbon monoxide, a colorless, odorless, poisonous gas. Breathing carbon monoxide will cause nausea, dizziness, fainting or death. If you start to feel dizzy or weak, get fresh air immediately.

ALWAYS OPERATE EQUIPMENT OUTDOORS ONLY, IN A WELL VENTILATED AREA.

NEVER operate the Outdoor Power Equipment inside any building, including garages, basements, sheds or other confined spaces.

DO NOT allow exhaust fumes to enter a confined area through windows, doors, vents or other openings while operating the tiller.

⚠ DANGER

Using an engine indoors **CAN KILL YOU IN MINUTES**. Engine exhaust contains carbon monoxide. This is a poison you cannot see or smell.



⚠ DANGER

DO NOT allow untrained individuals or children to use this unit.

⚠ DANGER

Rotating parts can entangle hands, feet, hair, clothing and/or accessories. Traumatic amputation or severe laceration can result.

Keep hands and feet away from rotating parts.

Tie up long hair and remove jewelry.

Operate equipment with guards in place.

DO NOT wear loose-fitting clothing, dangling drawstrings or items that could become caught.

⚠ WARNING

Before operating your machine, carefully read and understand all safety, controls and operating instructions in this Operator's Manual.

Failure to follow these instructions can result in serious personal injury.

⚠ WARNING

Clear the work area before each use. Remove all objects such as rocks, broken glass, nails, wire, or string which can be thrown or become entangled in the machine.

Always wear eye protection with side shields marked to comply with ANSI Z87.1. Failure to do so could result in objects being thrown into your eyes and other possible serious injuries.

Keep all bystanders, children, and pets at least 50' (15m) away when operating the unit.

Always wear sound protection (ear muffs or ear plugs) to reduce the risk of hearing loss associated with long term engine sound level(s).

Always wear heavy long pants, boots, gloves, and a long sleeve shirt. Do not wear loose clothing, jewelry, short pants, sandals, or go barefoot. Secure long hair so it is above shoulder level to prevent entanglement in rotating parts while operating this unit.

Do not operate this unit when you are tired, ill, or under the influence of alcohol, drugs, or medication.

Do not operate in poor lighting.

Always wear a face filter mask in dusty conditions to reduce the risk of injury associated with the inhalation of dust.

Keep firm footing and balance. Maintain a firm grip on the handle with both hands while using the tiller.

Do not overreach. Overreaching can result in loss of balance or exposure to hot contact surfaces or rotating parts.

Always inspect the unit before each use for loose fasteners, fuel leaks, etc. Replace damaged parts.

Use only identical manufacturer's replacement parts and accessories. Use of any other replacement parts may create a hazard or cause product damage and void your warranty.

Maintain the equipment per maintenance instructions located in this Operator's Manual.

⚠ DANGER

Rotating blades can cause severe bodily injury. Stop the engine and ensure blades have stopped rotating before installing/ changing parts or performing maintenance.

⚠ WARNING

Never till near underground electric cables, telephone lines, pipes or hoses.

It is recommended to contact your utility provider or diggers hotline in your area before tilling the ground.

⚠ WARNING

Running engines produce heat. Severe burns can occur on contact. Combustible material can catch fire on contact.

DO NOT touch hot surfaces.

Avoid contact with hot exhaust gases.

Allow equipment to cool before touching.

Maintain at least 3 ft. (91.4 cm) of clearance on all sides to ensure adequate cooling.

Maintain at least 5 ft. (1.5 m) of clearance from combustible materials.

⚠ WARNING

Rapid retraction of the recoil cord will pull hand and arm towards the engine faster than you can let go. Broken bones, fractures, bruises or sprains could result. Unintentional startup can result in entanglement, traumatic amputation or laceration.

When starting the engine, pull the recoil cord slowly until resistance is felt and then pull rapidly to avoid kickback.

⚠ CAUTION

Prolonged exposure to vibrations, also known as vibration white finger, through use of gasoline-powered equipment, such as this tiller, could cause blood vessel or nerve damage in fingers, hands, and joints. If symptoms occur such as numbness, or loss of feeling in the fingers, hands, or joints, discontinue the use of this tiller and seek medical attention.

Fuel Safety**⚠ DANGER****GASOLINE AND GASOLINE VAPORS ARE HIGHLY FLAMMABLE AND EXPLOSIVE.**

Fire or explosion can cause severe burns or death.

Gasoline and gasoline vapors:

Gasoline is highly flammable and explosive.

Gasoline can cause a fire or explosion if ignited.

Gasoline is a liquid fuel, but its vapors can ignite.

Gasoline is a skin irritant and needs to be cleaned up immediately if spilled on skin or clothes.

Gasoline has a distinctive odor; this will help detect potential leaks quickly.

Gasoline expands or contracts with ambient temperatures. Never fill the gasoline tank to full capacity, as gasoline needs room to expand when temperatures rise.

In the case of any petroleum gasoline fire, flames should never be extinguished unless the fuel supply valve can be turned OFF. By not doing so, if a fire is extinguished and the supply of fuel is not turned OFF, an explosion hazard could be created.

When adding or removing gasoline:

DO NOT light or smoke cigarettes while handling gasoline.

Always store or transfer gasoline in an EPA/CARB compliant fuel tank.

Never pump gasoline directly into the tiller at the gas station.

Always drain gasoline outdoors in a well-ventilated area.

Always loosen fuel cap slowly to release vapor pressure and to keep fuel from escaping around the fuel cap.

Always replace and tighten the fuel cap securely after fueling.

Always stop the engine and allow it to cool for a minimum of two minutes before refueling.

Never remove the fuel cap or add fuel while the engine is running or when the engine is hot.

DO NOT overfill the gasoline tank.

DO NOT tip the tiller and allow fuel or oil to spill.

In the event of spilled fuel, wipe the fuel from the tiller and move 10 ft. (3m) away from refueling site before starting the engine to avoid potential ignition of fuel vapors.

Save these instructions. Refer to them frequently and use them to instruct others who may use this product. If you loan this equipment, provide these instructions also.

When starting the tiller:

DO NOT attempt to start a damaged tiller.

Always check that the gasoline cap, air filter, spark plug, fuel lines and the exhaust system are properly in place.

Always be certain that the tiller is resting firmly on level ground.

When operating the tiller:

Do not put hands or feet near or under rotating parts.

Never use the tiller without the proper guards, shields, plates or other safety protective devices are in place.

Do Not till in reverse.

Always completely stop the engine and disconnect the spark plug wire prior to inspecting the unit due to striking a solid object, excessive vibration, clearing rocks or debris from the tines or making repairs or adjustments.

When transporting or servicing the tiller:

Always check that the fuel valve is in the OFF position and the gasoline tank is empty.

Disconnect the spark plug wire.

When storing the tiller:

Always store tiller and gasoline in a cool, well-ventilated area, safely away from sparks, open flames, pilot lights, heat and other sources of ignition.

▲ WARNING

Never use a gasoline container, gasoline tank, or any other fuel item that is broken, cut, torn or damaged.

Safety Symbols

Some of the following symbols may be used on this product. Please study them and learn their meaning. Proper interpretation of these symbols will allow you to safely operate the product.

SYMBOL	MEANING
	Read Operator's Manual. To reduce the risk of injury, user must read and understand operator's manual before using this product.
	Eye and Ear Protection. Always wear safety goggles or safety glasses with side shields, and as necessary a full face-shield as well as full ear protection when operating this product. Always wear eye protection with side shields marked to comply with ANSI Z87.1.
	Footwear. Always wear safety shoes or heavy boots when operating the machine.
	Gloves. Always wear nonslip, heavy-duty protective gloves when operating this product.
	Safety Alert. This machine was built to be operated according to the safe operation practices in this manual. As with any type of power equipment, carelessness or error on the part of the operator can result in serious injury. This machine is capable of amputating fingers, hands, toes and feet and throwing foreign objects. Failure to observe the safety instructions could result in serious injury or death.
	Risk of Fire. Fuel and its vapors are extremely flammable and explosive. Fire can cause severe burns or death. Do not add fuel while the product is operating or still hot.
	Hot Surface. To reduce the risk of injury or damage, avoid contact with any hot surface.
	Open Flame Alert. Fuel and its vapors are extremely flammable and explosive. Keep fuel away from smoking, open flames, sparks, pilot lights, heat, and other ignition sources.
	Toxic Fumes. The engine exhaust from this product contains chemicals known to cause cancer, birth defects and other reproductive harm. Risk of Asphyxiation. This engine emits carbon monoxide, an odorless, colorless poison gas. Breathing carbon monoxide can cause nausea, fainting or death. Use only in a well-ventilated area.
	Clearance. Keep all objects including others at least 10 feet (3m) from this machine. Only one person should operate the tiller and load the logs.
	Rotating Tines. Avoid injury from rotating tines. Keep hands away.
	Rotating Tines. Avoid injury from rotating tines. Keep feet away.
	Thrown Objects. This machine may pick up and throw objects which can cause serious personal injury.

KNOW YOUR PRODUCT

Read this operator's manual before operating your tiller. Familiarize yourself with the location and function of the controls and features.

Save this manual for future reference.

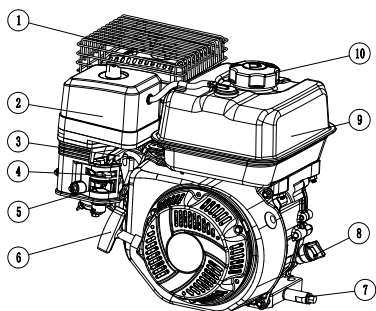

Engine

1	Muffler guard
2	Air filter
3	Throttle Lever
4	Choke lever
5	Fuel valve
6	Recoil starter handle
7	Oil drain bolt
8	Oil fill cap/dipstick
9	Fuel tank
10	Fuel tank cap

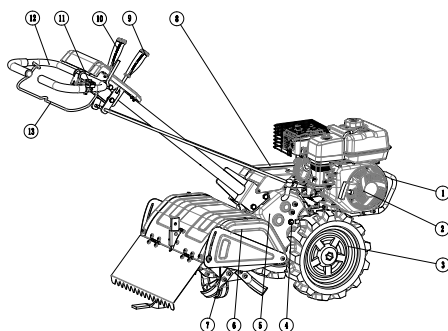

Tiller

1	Bumper
2	Engine
3	Wheel
4	Oil level sight glass
5	Transmission
6	Tines shield
7	Tines
8	Belt guard
9	Tine rotation select handle
10	Wheel drive select handle
11	Ignition & throttle control
12	Upper handlebar (operation handle)
13	Clutch control bar

ASSEMBLY

Your tiller requires some assembly. This unit ships from our factory without oil. It must be properly serviced with fuel and oil before operation.

If you have any questions regarding the assembly of your tiller, call our Technical Support Team at 1-800-409-7802. Please have your serial number and model number available.

UNPACKING

1. Remove any banding and open carton from top.
2. Remove all loose packed items and packaging inserts.
3. With assistance, remove the tiller from the carton.
4. Remove all additional loose items from packaging materials. Do not discard packaging until you have confirmed all components are present.

PARTS INCLUDED

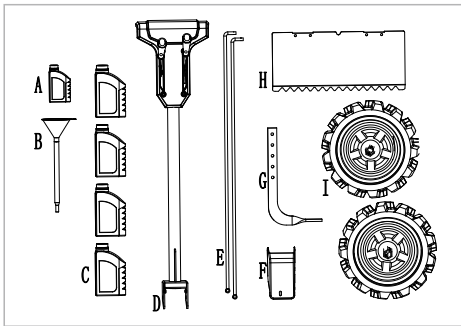

A	Engine oil bottle
B	Oil funnel
C	4 x Transmission oil bottle
D	Lower handle tube
E	2 x Shift linkage rod
F	Control cover plate
G	Drag stake
H	Tine shield
I	2 x Wheel

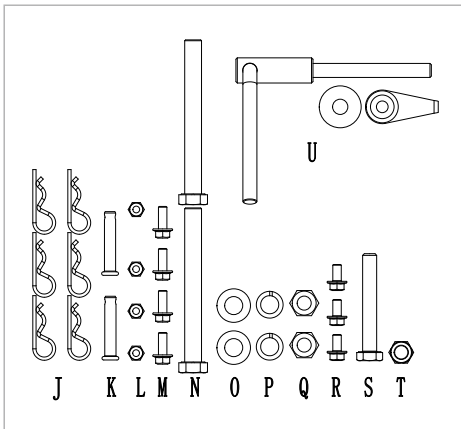

J	6 x Hair pin
K	2 x Clevis pin
L	4 x Hex flange nut M6
M	4 x Hex flange bolt M6x16
N	2 x Bolt M12x110
O	2 x Washer 12
P	2 x Split lock washer 12
Q	2 x Nut M12
R	3 x Bolt M6x12
S	Bolt M10x70
T	Nut M10
U	Handle height adjustment bolt

Tools Kit Content: Tools Required

- 17 mm / 19 mm Wrench - Qty 1
- 13 mm / 16 mm Wrench - Qty 1
- 12 mm / 14 mm Wrench - Qty 1
- 8 mm / 10 mm Wrench - Qty 1
- Phillips screwdriver - Qty 1

Install the Wheels

Prior to the installation of the wheel & tire assemblies (1) identify the Right & Left side wheel. Note: Proper orientation is with the tread pattern forward facing "Λ" (see below). With assistance, lift the tiller unit upwards, install the wheel and tire assemblies onto the axle shaft. Align the hole furthest from the wheel & tire assembly with the hole in the axle shaft and insert clevis pin (2), secure with hair pin (3).

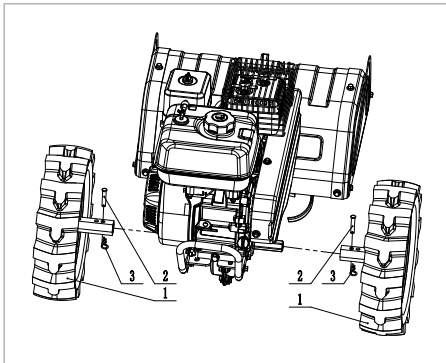

Attach Lower Handle

1. Using the two M12*110 Bolts (2), split lock washers, washers and nuts (3,4,5) install the lower handle tube (1) as shown. (19mm wrench & adjustable wrench)

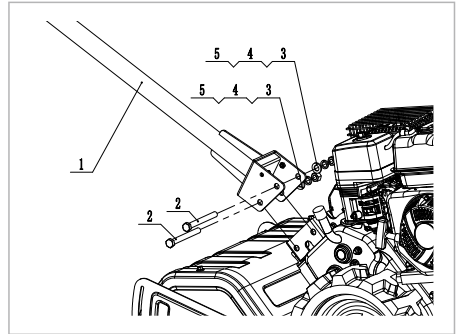

Attach Upper Handle

1. Install upper handle (1) using the bolt M10*70 (2) and lock nut M10 (3).

NOTE

The On/Off switch -throttle control is on the top, the tine engagement bail is below the handle. Attention must be given to ensure the cables are not twisted or caught in the linkage.

2. Install the upper handle height adjustment bolt (4) into the slotted hole of the upper handle tube. When tightening ensure the black lock nut (6) tang is engaged in the hole of the upper handle tube. (as shown)

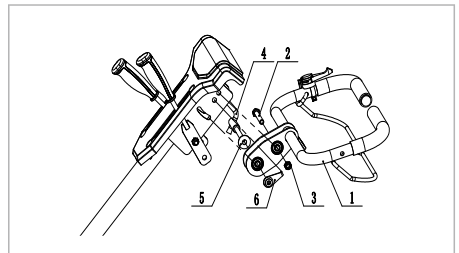

3. Secure the two shift linkage rods(1) to the upper Shift Levers and the lower shift linkage with cotter pins (2), as shown in the figure.

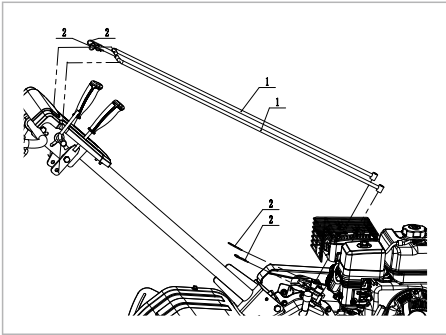

4. Install transmission cover plate (1) using 3 Bolt M6*12 (2).

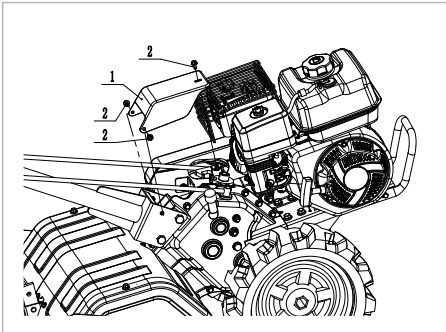

Install the Drag Stake

Remove the drag stake clevis pin, which is preinstalled in the drag stake pocket at the rear of the tiller. Insert the drag stake (1) with the foot facing back. Reinstall the clevis (2) and hair pin (3).

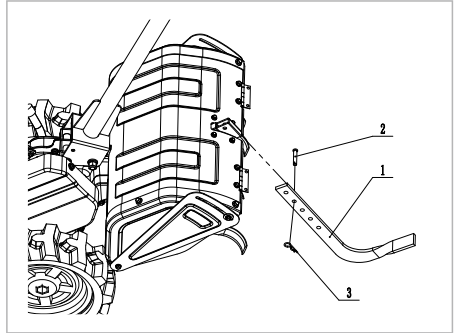

Install the Tine Shield

Install the Tine Shield (1) using 4 Bolts M6*16 (2) and 4 Lock Nuts M6 (3) .

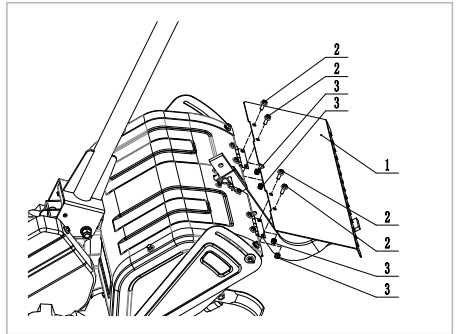

OPERATION

⚠ WARNING

Before operating your machine, carefully read and understand all safety, controls and operating instructions in this Operator's Manual.

Failure to follow these instructions can result in serious personal injury.

Introduction

Read this section before you start the engine. Then, take the time to familiarize yourself with the basic operation of the tiller before using it in the garden. Find an open, level area and practice using the tiller controls without the tines engaging the soil. Only after you've become completely familiar with the tiller should you begin using it in the soil.

Add Fuel

⚠ DANGER

Gasoline vapors are highly flammable and extremely explosive.

DO NOT light or smoke cigarettes.

Fire or explosion can cause severe burns or death.

Only fill or drain fuel outdoors in a well-ventilated area.

DO NOT pump gasoline directly into the engine.

Use an approved container to transfer the fuel to the engine.

Never use a gasoline container, gasoline tank, or any other fuel item that is broken, cut, torn or damaged.

DO NOT overfill the gasoline tank.

Always keep fuel away from sparks, open flames, pilot lights, heat and other sources of ignition.

Use clean, fresh, regular unleaded gasoline with a minimum octane rating of 87 and an ethanol content of 10% or less by volume.

DO NOT mix oil with gasoline.

1. Remove the fuel tank cap.
2. Slowly add gasoline to the tank. **DO NOT** OVERFILL.

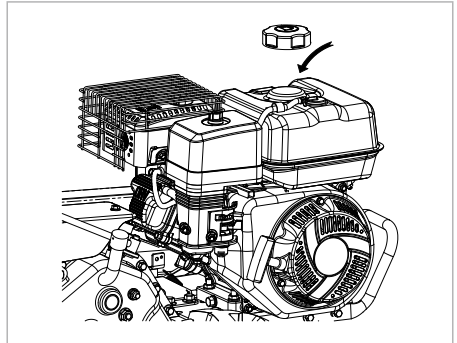

💬 NOTE

Gasoline can expand after filling. A minimum of ¼ in. (6.4 mm) of space left in the tank is required for gasoline expansion although more than ¼ in. (6.4 mm) is recommended. Gasoline can be forced out of the tank as a result of expansion if overfilled and can affect the stable running condition of the tiller.

⚠ CAUTION

Use unleaded gasoline with a minimum octane rating of 87 and an ethanol content of 10% or less by volume.

DO NOT light cigarettes or smoke when filling the tank.

DO NOT mix oil and gasoline.

DO NOT overfill the tank. Fill tank to approximately ¼ in. (6.4 mm) below the top of the tank to allow for gasoline expansion.

DO NOT pump gasoline directly into the engine at the pump.

Use an approved fuel container to transfer gasoline to the engine.

DO NOT fill the tank indoors.

DO NOT fill the tank when the engine is running or hot.

⚠ WARNING

Pouring gasoline too fast through the fuel screen may result in blowing back of gasoline at the operator while filling.

💬 NOTE

The engine works well with 10% or less ethanol blended gasoline. When using ethanol-gasoline blends there are some issues worth noting:

Ethanol-gasoline blends can absorb more water than gasoline alone.

These ethanol blends can eventually separate, leaving water or a watery good in the tank, fuel valve and carburetor. The compromised gasoline can be drawn into the carburetor and cause damage to the engine and/or create potential hazards.

If a fuel stabilizer is used, confirm that it is formulated to work with ethanol-gasoline blends.

Any damages or hazards caused by using ethanol blended gasoline higher than 10% by volume, improperly stored gasoline, and/or improperly formulated stabilizers, are not covered by manufacturer's warranty.

It is advisable to always shut off the gasoline supply and run the engine to starvation after each use. See Storage instructions for extended non-use.

Add Engine Oil**⚠ CAUTION**

This unit ships from our factory without oil. It must be properly serviced with fuel and oil before operation. DO NOT attempt to crank or start the engine before it has been properly filled with the recommended type and amount of oil.

Damage to the engine as a result of failing to follow these instructions will void your warranty.

💬 NOTE

The recommended oil type is 10W-30 automotive oil.

1. Place the tiller on a flat, level surface.
2. Remove oil fill cap/dipstick to add engine oil.
3. Using a funnel, add up to 20.6 fl. oz. (600 ml) of oil and replace oil fill cap/dipstick. DO NOT OVERFILL.
4. Check the engine oil level and add as needed.

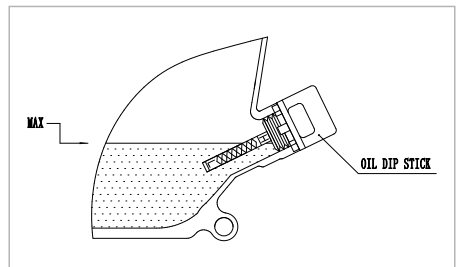
**💬 NOTE**

Once oil has been added, a visual check should show oil about 1-2 threads from running out of the fill hole.

When using the dipstick to check oil level, DO NOT screw in the dipstick while checking.

Add Transmission Oil

⚠ CAUTION

The transmission is shipped without oil from the factory.

Place the tiller on a level surface. Using the supplied funnel (B) add 4.25 quarts (136 oz) of 10W-30 oil (C) at the transmission fill plug location.

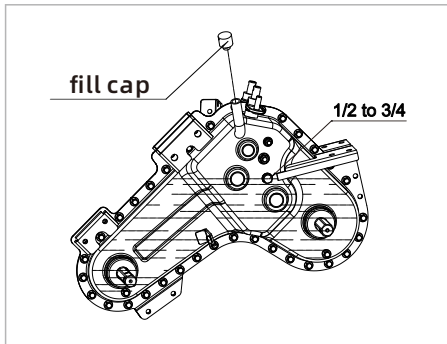

Starting the Engine

1. Check the oil level and add oil if necessary.
2. Make certain the tiller is on a flat, level surface.
3. Place both shift handles (Tine & Wheel drive) into the neutral position.
4. Turn engine ON / OFF switch to the "ON" position (located on right side upper handlebar).
5. Rotate the throttle lever clockwise until it stops in the high-speed position.
6. Slide the Choke lever on engine fully to the left (Full Choke position).
7. Slide Fuel Valve fully to the right (Open position).
8. Pull the starter handle slowly until resistance felt, then pull rapidly.
9. Once the engine starts, slide the choke lever to the off position.
10. Control engine speed with the throttle control located on the upper handle.

Clutch Control Bar Operation

The Clutch Control Bar governs the power transmission for both the wheel drive and tine rotation (i.e., enabling or disabling power delivery to the wheels drive and tiller tines rotation).

After starting the engine, set the tine rotation select handle or wheel drive select handle to the desired position, then pull the control bar upward to engage the working or driving mode. Upon releasing the clutch control bar, power transmission is cut off, and both the wheel and tine rotation will stop.

⚠ WARNING

All select handle operations must be performed with the clutch control bar in the released position.

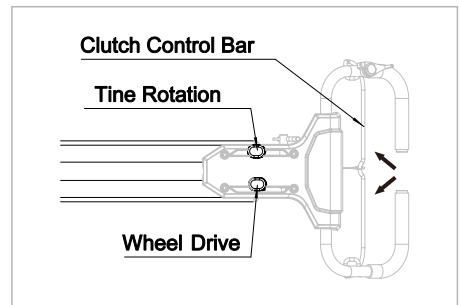

Wheels Drive Operation

⚠ WARNING

Do not attempt to engage the tines or wheels until you have read all the operating instructions.

Keep away from rotating tines. Rotating tines will cause injury.

After starting the engine, pull the wheel drive select handle backward and pull the clutch control bar upward—the wheel will move forward. Release the clutch control bar and the wheels will stop drive.

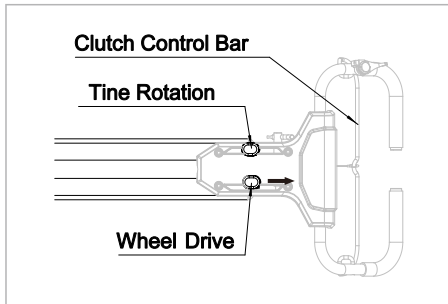

Push the wheel drive select handle forward and pull the clutch control bar upward—the wheels will move backward. Release the clutch control bar and the wheels will stop drive.

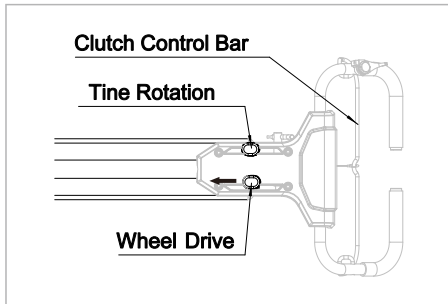

Tines Rotation Operation

Forward Rotary Tilling: When tilling soft soil, place the wheel drive select handle in "F" position (pull backward) and the Tine rotation select handle in "F" position (Push forward) . Pull the clutch control bar upward—the wheels will move forward and the tines will rotate for forward tilling (see figure).

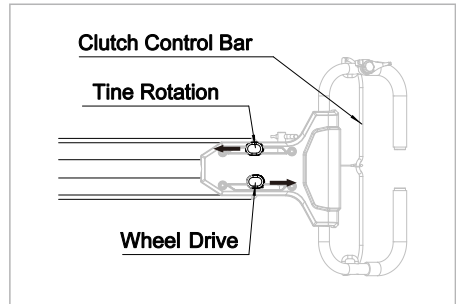

Reverse Rotary Tilling: When tilling hard soil, place the wheels drive select handle in "F" position (Pull backward) and the Tines rotation select handle in "R" position (Pull backward). Pull the clutch control bar upward—the wheels will move forward and the tines will rotate for reverse tilling (see figure).

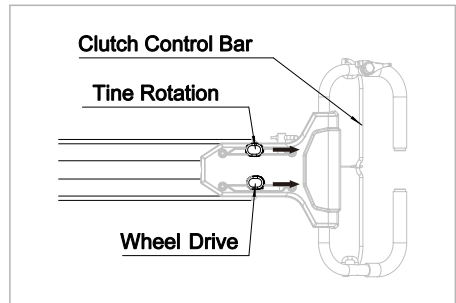

Releasing the clutch control bar, both the wheel and tine rotation will stop.

⚠ WARNING

DO NOT till in reverse.

NOTE

During operation, pay attention to the working condition and sounds of all components. Check that all connections are normal and ensure there are no loose parts. If any abnormalities are detected, stop the machine immediately for inspection and troubleshooting.

Do not immediately subject the machine to heavy loads after starting with a cold engine. This is especially important for new machines or those that have undergone major repairs.

Regularly check the oil levels in the engine, gearbox, and tillage transmission. Replenish the oil immediately if it is insufficient.

It is prohibited to cool the engine by pouring water on it.

Take care to prevent the tiller from tipping over during tilling operations.

It is strictly forbidden to operate the tiller with the tines installed on hard or rocky surfaces, as this may damage the tines.

After use, please ensure that mud, weeds, oil stains, and other debris are cleaned off the machine to keep the entire unit clean.

Stopping the Engine and the Tiller

In an emergency, rotate the engine On-Off switch clockwise to the "Off" position.

under normal operation:

1. To stop the wheels and tines, release clutch control bar.
2. Shift all select handle (wheel drive and tiller tine rotation) to the neutral position.
3. To stop the engine, slide the throttle lever back(towards the operator) to the slow/idle position.
4. Rotate the engine On-Off switch clockwise to the "Off" position.
5. Slide the fuel valve lever to the "OFF" position.

Choosing Correct Wheel and Tine Speeds

With experience, you will find the "just right" tilling depth and tilling speed combination that is best for your garden.

Set the engine throttle lever at a speed to give the engine adequate power and yet allow it to operate at the slowest possible speed ... at least until you have achieved the maximum tilling depth you desire. Faster engine speeds may be desirable when making final passes through the seedbed or when cultivating. Selection of the correct engine speed, in relation to the tilling depth, will ensure a sufficient power level to do the job without causing the engine to labor.

Let the Tiller Do the Work

While tilling, relax and let the wheels pull the tiller along while the tines do the digging. Walk on the side that is not yet finished (to avoid making footprints in the freshly tilled soil) and lightly, but securely grip the handlebar with just one hand.

Avoid Tilling Soggy, Wet Soil

Tilling wet soil often results in large, hard clumps of soil that can interfere with planting. If time permits, wait a day or two after heavy rains to allow the soil to dry before tilling. Test soil by squeezing it into a ball. If it compresses too easily, it is too wet to till.

MAINTENANCE

WARNING

Before inspecting, cleaning or servicing the machine, shut off the engine, wait for all moving parts to come to a complete stop, disconnect spark plug wire and move wire away from spark plug.

Failure to follow these instructions can result in serious personal injury or property damage.

NOTE

For Emission control devices and systems, read and understand your responsibilities for service as stated in the Emission Control Warranty Statement.

RECOMMENDED MAINTENANCE SCHEDULE

Recommended Maintenance Schedule		Each Use	First 20 Hours or 1 Month	Every 3 Months or 50 Hours	Every 100 Hours or Every Season	Before Storage
Engine Oil	Check Level	X				
	Replace		X		X	
Air Filter	Check			X		
	Clean			X		
Fuel	Check Level	X				
	Drain					X
Carburetor	Drain					X
Throttle Cable	Check	X				
Forward / Reverse lever	Check	X				
Belt Tension	check / Adj		X		X	
Transmission oil	check / Adj	X				

Check for Oil Leaks

Before each use, check the tiller for signs of an oil leak — usually a dirty, oily accumulation either on the unit or on the floor.

If a cover is leaking, check for loose screws. If the screws are tight, a new gasket or oil seal may be required.

Check Hardware

Check for loose or missing hardware after every 10 operating hours and tighten or replace (as needed) before reusing the tiller.

Be sure to check the screws underneath the tiller hood that secure the transmission cover and the Depth Drag stake to the transmission.

Transmission Oil Service

Check the transmission oil level after every 30 hours of operation or whenever you notice any oil leak. Operating the tiller when the transmission is low on oil can result in severe damage.

To Check the Transmission Oil Level:

1. Check the transmission oil level when the transmission is cool. Transmission oil will expand in warm operating temperatures and this expansion will provide an incorrect oil level reading.
2. With the tiller on level ground, pull the Drag Stake all the way up.
3. The transmission oil level is correct if it exceeds half of the oil level sight glass.
4. If the transmission oil level is low, add transmission oil (SAE 10W-30).

IMPORTANT: Do not operate the tiller if the transmission oil level is low. Doing so will result in severe damage to the transmission components.

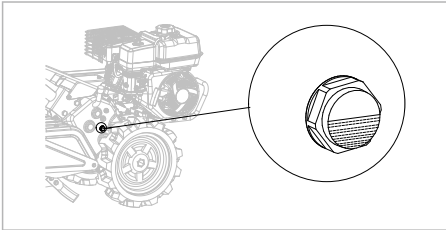

3. Tighten the oil drain bolt securely with the 10 mm wrench.
4. Remove the oil fill cap, Use an oil funnel to pour new oil into the transmission through the fill opening. Check the oil level sight glass and fill until the oil level reaches 1/2-3/4 of the sight glass.

Check and Adjust Tine Drive Belt Tension

It is important to maintain correct tension on the forward and reverse tine drive belt.

A loose belt will cause the tines to slow down or stop completely, even though the engine is running at full speed.

A too-tight belt can result in unintentional tine movement when the lever is in the Neutral (released) position.

Check belt tension after the first 20 hours of break-in operation and after every 100 operating hours.

At the end of each tilling season, check the belt for cracks, cuts, or frayed edges, and replace it as soon as possible.

Change the Transmission Oil

1. Place a container under the transmission case.
2. Using a 10 mm wrench, remove the drain bolts from the bottom of both the wheel drive and tine drive gearboxes. Collect the waste oil in the container.

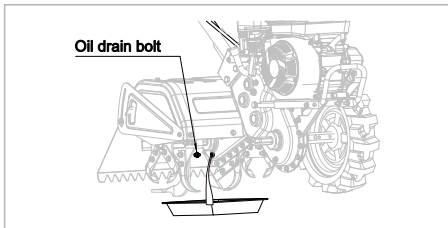
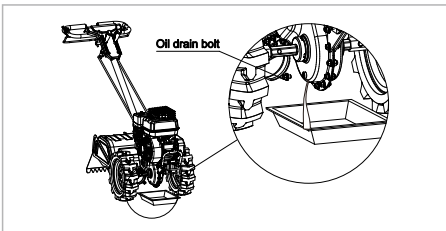

Check Belt Tension

1. Stop the engine, wait for all parts to stop moving, and disconnect the spark plug wire.
2. Remove the belt cover by loosening the bolts with 10mm and 12mm wrenches.
3. Move the wheel drive select handle to the F position (pull backward) or R position (push forward) to engage the belt tensioner (idler) pulley and tighten the belt.
4. Measure the tensioned belt distance as shown in the figure. If this distance is under 25mm, about 1 in., the belt is too loose and requires adjustment.

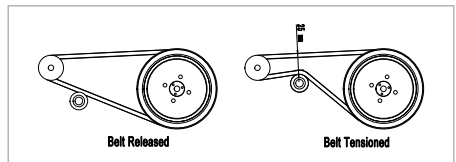

Adjust the Clutch Cable Length

The clutch cable adjustment nut is used to adjust the distance described above.

1. Rotate the adjustment nut counterclockwise as shown in the figure below.

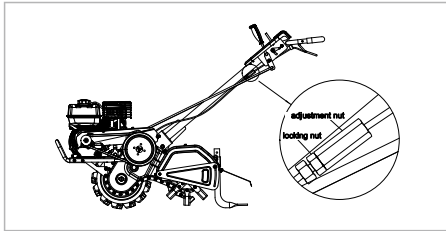

2. Adjust the nut by approximately 3/16 in. (5 mm) at a time.
3. Measure the belt distance again as shown in the previous figure.
4. Once the adjustment is complete and verified, rotate the locking nut counterclockwise to secure it.

NOTE

If there is no more cable adjustment left the belt has become stretched and will need replaced.

Remove the Belt

With the engine Off and spark plug wire removed.

1. Remove the belt cover.
2. Gently pull the engine recoil handle to rotate the engine pulley.
3. While the pulley turns, guide the belt out of the groove and off the pulley.
4. Pull the belt down and out of the way.
5. Remove the belt from the transmission pulley by guiding it out of the groove.

Install the Belt

1. Place the belt in the transmission pulley groove.
2. Gently pull the engine recoil rope to rotate the engine pulley while guiding the belt into the groove.
3. Check belt tension distance by following the procedure of Check Belt Tension. If the distance exceeds 1 in. (25 mm), adjust it using the adjustment nut. If necessary, loosen the four engine mount bolts and move the engine to achieve the correct distance.

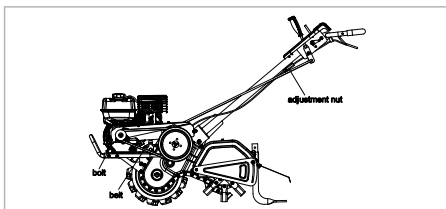

4. Install the pulley cover.

Tines

The tines will wear with use and should be inspected at the beginning of each tilling season and after every 30 operating hours. The tines can be replaced either individually or as a complete set. Refer to the parts list for tine identification and part numbers.

A. Tine Inspection:

With use, the tines will become shorter, narrower and pointed. Badly worn tines will result in a loss of tilling depth, and reduced effectiveness when chopping up and turning under organic matter.

B. Removing/Installing a Single Tine:

1. With the engine shut off and the spark plug wire disconnected, remove the M10x25 bolt, lock washer, flat washer and M10 nut that attach a single tine to a tine holder. If needed, use penetrating oil on the nuts.
2. When installing a single tine, be sure to position it so that its cutting edge (sharp) will enter the soil first as the tiller moves forward. Hand tightens completely.

C. Removing/Installing a Tine Assembly:

1. A tine assembly consists of eight tines mounted on a tine holder.
2. If removing both tine assemblies, mark them "left" and "right" before removal. Remove (2) pins and (2) cotter pins that secure the tine assembly to the tine shaft. If necessary, use a rubber mallet to tap the tine assembly outward off the shaft.
3. Before reinstalling the tine assembly, inspect the tine shaft for rust, rough spots or burrs. Lightly file or sand, as needed. Apply a thin coat of grease to the shaft.
4. Install each tine assembly so that the cutting (sharp) edge of the tines will enter the soil first when the tiller moves forward.

Engine Cleaning

Keeping the engine clean will help to ensure smooth operation and prevent damage from overheating. Be sure that the muffler is cool before servicing the engine.

Air Cleaner Service

The air cleaner filters dirt and dust out of the air before it enters the carburetor. Operating the engine with a dirty, clogged air filter can cause poor performance and damage to the engine. Never operate the engine without the air cleaner installed. Inspect and service the air cleaner more often if operating in dusty or dirty conditions.

Engine Oil Service

Check the engine oil level before each use and after every five hours of continuous operation. Running an engine when its low on oil will cause severe internal damage.

It is recommended to change the engine oil after the first 20 hours of operation and even sooner when operating in extremely dirty or dusty conditions.

A. To Check the Engine Oil Level:

1. Move the unit to a flat, level surface and shut off the engine.
2. On engines with a dipstick, remove it and wipe it clean. Reinsert the dipstick and remove it. Add oil as needed to bring the level up to the FULL mark. Wipe dipstick clean each time oil level is checked. Do not overfill. Tighten dipstick securely

B. To Change the Engine Oil:

CAUTION

DO NOT attempt to crank or start the engine before it has been properly filled with the recommended type and amount of oil. Damage to the tiller as a result of failure to follow these instructions will void your warranty.

NOTE

The recommended oil type is 10W-30 automotive oil.

1. Place a suitable container below the oil drain plug to catch the used oil.
2. Remove the oil drain plug from the engine and allow the oil to completely drain.
3. Reinstall and tighten the oil drain plug.
4. Add up to 20 fl. oz (0.6L) of oil to the engine at the oil fill cap / dipstick port.
5. Check the oil level using the dipstick. Do not screw in when checking.
6. When finished screw in the oil fill cap / dipstick securely.

NOTE

Once oil has been added, a visual check should show oil about 1-2 threads from running out of the fill hole.

If using the dipstick to check oil level, DO NOT screw in the dipstick while checking.

Weather will affect engine oil and engine performance. Change the type of engine oil used based on weather conditions to suit the engine needs.

Air Cleaner Maintenance

A dirty air cleaner can restrict air flowing into the carburetor. To keep the carburetor in good working conditions, please service the air cleaner periodically. If operating the engine in an extremely dusty area, service should be done more often.

⚠ WARNING

Never clean the air cleaner element with gasoline or low flashpoint detergents, an explosion may happen.

💬 NOTE

Never run the engine without an air cleaner. Dirty air entering the engine can speed up engine wear.

1. Remove the wing nut and the air cleaner cover. Remove the elements and separate them. Carefully check both elements for holes or tears and replace them if damaged.
2. Foam element: Wash the element in a solution of household detergent and warm water, then rinse thoroughly. Allow the element to dry thoroughly.
3. Paper element: Tap the element lightly several times on a hard surface to remove excess dirt or blow compressed air at a low pressure through the filter from the inside out. Never try to brush the dirt off; brushing will force dirt into the fibers. Replace the paper element if it is excessively dirty.

Spark Plug Service

Spark plug type: F7TC/F7RTC

For normal engine operation, ensure the spark plug gap is correct and check for carbon deposits around it.

1. Remove the spark plug cap.
2. Clear away dirt around the spark plug base.
3. Use a spark plug wrench to remove the spark plug.
4. Visually check the spark plug. Clean with a steel brush. If the insulator is damaged, replace the spark plug.
5. Measure the plug gap with a suitable gauge. Correct the gap as needed by carefully bending the electrode. Plug Gap: 0.030 (0.7 - 0.8mm)
6. Thread the spark plug in by hand to prevent cross-threading, then tighten with a spark plug wrench. Reinstalling a used plug - tighten $\frac{1}{8}$ - $\frac{1}{4}$ turn after the spark plug seats to seal the washer. Installing new plug - Tighten $\frac{1}{2}$ turn after the spark plug seats to compress the washer.

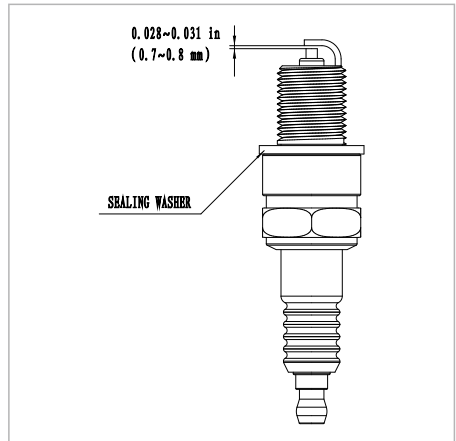
**💬 NOTE**

The spark plug must be tightened securely, or it may become very hot and damage the engine.

TRANSPORTATION AND STORAGE

Transport around the yard

1. Move the Drag Stake down to the second top hole for transporting the tiller.
2. Place the Wheel Drive Shift handle to F1 position for transporting.
3. Place the Tine shift handle to the neutral position. Tines will not turn.

⚠ WARNING

Fuel is extremely flammable and explosive under certain conditions. Keep smoking, fire and spark away from the operating site.

Off-Season Storage

When the tiller won't be used for an extended period longer than 30 days, prepare it for storage as follows:

1. Select a well-ventilated dry storage area away from a source to open flames or spark producing products.
2. Drain the fuel tank completely.
3. Start the engine and run until it stops. This helps prevent gum deposits from forming inside the carburetor and possible engine damage.
4. While the engine is still warm, drain the oil from the engine. Refill with fresh oil.
5. Use clean clothes to clean off the outside of the machine and to keep the air vents free of obstruction.
6. Check for loose parts and hardware.
7. Turn the fuel valve to "OFF" position.
8. Remove the spark plug. Place about a teaspoon (5cc) of fresh engine oil into the cylinder. Pull the starter handle several times to distribute engine oil evenly.
9. Reinstall the spark plug.

TROUBLESHOOTING

Problem	Cause	Solution
Engine does not start	Spark plug wire disconnected.	Reconnect wire.
	Engine Throttle Control Lever incorrectly set.	Move the throttle lever to the Fast position.
	Fuel tank is empty.	Refuel.
	Choke control in incorrect position.	Move lever to CHOKE position.
	Stale gasoline.	Drain the fuel tank and carburetor. Refuel with fresh gasoline.
	Dirty air filter.	Clean or replace filter.
	Switch is in "OFF" position.	Turn switch to "ON" position.
	Defective or incorrectly gapped spark plug.	Gap or replace spark plug.
Engine runs poorly	No spark.	Check engine switch is in ON position, Check oil level, Check / replace spark plug.
	Defective or incorrectly gapped spark plug.	Inspect spark plug gap or replace spark plug.
	Dirty air filter(s).	Clean or replace the air filter.
Engine overheats	Stale gasoline.	Drain the fuel tank and carburetor. Refuel with fresh gasoline.
	Engine cooling system clogged.	Clean cylinder cooling fins, recoil starter vents and behind engine shrouds.
Poor tilling performance	Oil level is low.	Add engine oil.
	Worn tines.	Replace worn or damaged tines.
	Incorrect throttle setting.	Adjust throttle on engine or speed control on handelbar to highest setting.
	Drive Belt slipping.	Adjust pulley tension or replace belt.
The engine starts, then shuts down after a short period	The soil is too wet.	Wait a day or two after the rain for the soil to dry out.
	Air vent in the fuel tank cap is clogged.	Replace the fuel tank cap.
	Fuel valve is not fully open or is clogged.	Open fuel valve and / or have carburetor cleaned.
	Float in carburetor is damaged or sticking.	Have the carburetor cleaned.
	Fuel is contaminated or deteriorated.	Drain & replace the fuel in the fuel tank and carburetor bowl.
	There is water in the fuel.	Drain & replace the fuel in the fuel tank and carburetor bowl.
Abnormal cylinder compression	Carbon deposit and buildup on spark plug electrode.	Clean and re-gap or replace spark plug.
	Valves are out of adjustment.	Have the valve lash set to proper values.
Tiller moves forward during starting	Spark plug is not properly tightened, or gasket is missing.	Tighten with a gasket in.
	Tine Rotation Handle is not neutral position.	Tine Rotation Handle must be set to neutral position for starting.
Tiller is difficult to control when tilling (Machine jumps or lurches forward)	Improper tilling depth setting.	Raise the tines for shallower tilling by raising the depth of Drag Stake.
	Too high engine speed on hard ground.	Set the throttle lever at lower speed.
Tines do not engage	Tine Rotation Handle is in neutral position.	Set the Tine Rotation Handle in Forward or Reverse position.
	Foreign debris is lodged in between tines.	Stop tiller completely, remove and discard any foreign debris from tines.
	Tine pin missing.	Replace tine pin.

If engine still doesn't start, contact our Technical Support Team at 1-800-409-7802 Mon-Fri 8-4 CST or Email: support@novuspowerequipment.com.

BASIC SERVICE PARTS LIST**Common Service Parts**

Service Part	Part Number
Carburetor Assembly	1807900112-0001
Recoil Starter	2000200093-0002
Spark Plug -F7RTC	2204700003-0001
Air Filter Element Assembly	1903400012-0001
Fuel Hose	1816200026-0001
Transmission Fill Cap	2150600001-0001
Dipstick Assy	1101500002-0003
Clutch Cable	3009200136-0001
Throttle Cable	3000200034-0001
Ignition & Throttle Control	3022800002-0001
Clevis Pin	361020029
Hair Pin	3402200005-0003
Belt	2123600132-0001
Fuel Cap	1800900009-0001

WARRANTY STATEMENT

2-Year Limited Warranty Terms and Conditions

Novus products are warranted for two (2) years against defects in materials or workmanship when put to ordinary and normal consumer use; ninety (90) days for any other use.

For the purposes of all the above warranties, "ordinary and normal consumer use" refers to non-commercial residential use and does not include misuse, accidents or damage due to inadequate maintenance. Novus Performance Products LLC certifies that Novus Products are fit for ordinary purposes for which a product of this type is used. Novus Performance Products LLC, however, limits the implied warranties of merchantability and fitness in duration to a period of two (2) years in consumer use, ninety (90) days for any other use.

The 2-Year Limited Warranty on Novus Products starts on the purchase date. The 2-Year Limited Warranty is applicable only to the original owner.

The warranty holder is responsible for the performance of the required maintenance as defined by the manufacturer's owner's manuals. The warranty holder is responsible for replacement of normally wearing parts such as the Belt, Shear Pins, Spark Plug and Air Filter. Accessories to the machine are not covered by this warranty.

During the warranty period, the warranty holder is responsible for the machine transportation charges, if required.

During the warranty period, warranty parts will be shipped by standard method at no charge to the warranty holder. Expedited shipping of warranty parts is the responsibility of the warranty holder.

SOME STATES DO NOT ALLOW LIMITATIONS ON THE LENGTH OF IMPLIED WARRANTIES, SO THE ABOVE

LIMITATIONS MAY NOT APPLY TO YOU.

Novus Performance Products LLC shall not be liable under any circumstances for any incidental or consequential damages or expenses of any kind, including, but not limited to, cost of equipment rentals, loss of profit, or cost of hiring services to perform tasks normally performed by Novus Products.

SOME STATES DO NOT ALLOW THE EXCLUSION OR LIMITATION OF INCIDENTAL OR CONSEQUENTIAL DAMAGES, SO THE ABOVE LIMITATIONS MAY NOT APPLY TO YOU.

THIS WARRANTY GIVES YOU SPECIFIC LEGAL RIGHTS, AND YOU ALSO HAVE OTHER RIGHTS, WHICH VARY FROM STATE TO STATE.

Technical Support:

Toll free: 1-800-409-7802 Mon-Fri 8-4 CST

Email: support@novuspowerequipment.com

U.S. FEDERAL EMISSION CONTROL WARRANTY STATEMENT YOUR WARRANTY RIGHTS AND OBLIGATIONS

The United States Environmental Protection Agency and Novus Performance Products LLC (Novus) are pleased to explain the emissions control system warranty on your 2025-2026 small off-road engine/equipment (SORE). In the United States, new equipment that use small off-road engines must be designed, built, and equipped to meet the State's stringent anti-smog standards. Novus must warrant the emissions control system on your small off-road engine/equipment for the periods of time listed below there has been no abuse, neglect or improper maintenance of your small off-road engine or equipment leading to the failure of the emissions control system.

Your emissions control system may include parts such as the carburetor or fuel-injection system, the ignition system, catalytic converter, fuel tanks, fuel lines (for liquid fuel and fuel vapors), fuel caps, valves, canisters, filters, clamps and other associated components. Also included may be hoses, belts, connectors, and other emission-related assemblies.

Where a warrantable condition exists, Novus will repair your small off-road engine/equipment at no cost to you including diagnosis, parts and labor.

MANUFACTURER'S WARRANTY COVERAGE:

This emissions control system on your small off-road engine/equipment is warranted for two years. If any emission-related part on your small off-road engine/equipment is defective, the part will be repaired or replaced by Novus.

OWNER'S WARRANTY RESPONSIBILITIES:

As the small off-road engine/equipment owner, you are responsible for the performance of the required maintenance listed in your owner's manual. Novus recommends that you retain all receipts covering maintenance on your small off-road engine/equipment, but Novus cannot deny warranty coverage solely for the lack of receipts or for your failure to ensure the performance of all scheduled maintenance.

As the small off-road engine/equipment owner, you should however be aware that Novus may deny you warranty coverage if your small off-road engine/equipment or a part has failed due to abuse, neglect, or improper maintenance or unapproved modifications.

You are responsible for presenting your small off-road engine/equipment to a Novus distribution center or service center as soon as the problem exists. The warranty repairs shall be completed in a reasonable amount of time, not to exceed 30 days. If you have any questions regarding your warranty rights and responsibilities, you should contact:

Novus Performance Products LLC
customer service representative
1-800-409-7802
Email: Support@novuspowerequipment.com

DEFECTS WARRANTY REQUIREMENTS

(a) Applicability. This section applies to emissions control systems on small off-road engines or equipment that use small off- road engines subject to the emission standards in this Article. The warranty period begins on the date the engine or equipment is delivered to an ultimate purchaser and extends for a period of two years.

(b) General Emissions Warranty Coverage. The engine or equipment must be warranted to the ultimate purchaser and any subsequent owner that the emissions control system when installed was:

- (1) Designed, built, and equipped so as to conform with all applicable regulations; and
- (2) Free from defects in materials and workmanship that causes the failure of a warranted part for a period of two years.

(c) The warranty on emissions-related parts will be interpreted as follows:

- (1) Any warranted part that is not scheduled for replacement as required maintenance in the written instructions required by subsection (e) must be warranted for the warranty period defined in subsection (b)(2). If any such part fail during the period of warranty coverage, it must be repaired or replaced by Novus or it's contracted warranty provider according to subsection (4) below. Any such part repaired or replaced under the warranty must be warranted for a time not less than the remaining warranty period.
- (2) Any warranted part that is scheduled only for regular inspection in the written instructions required by subsection (e) must be warranted for the warranty period defined in subsection (b)(2). A statement in such written instructions to the effect of "repair or replace as necessary" shall advise owners of the warranty coverage for emissions related parts. Replacement within the warranty period is covered by the warranty and will not reduce the period of warranty coverage. Any such part repaired or replaced under warranty must be warranted for a time not less than the remaining warranty period.
- (3) Any warranted part that is scheduled for replacement as required maintenance in the written instructions required by subsection (e) must be warranted for the period of time prior to the first scheduled replacement point for that part. If the part fails prior to the first scheduled replacement, the part must be repaired or replaced by Novus according to Subsection (4) below. Any such part repaired or replaced under warranty must be warranted for a

time not less than the remainder of the period prior to the first scheduled replacement point for the part.

- (4) Repair or replacement of any warranted part under the warranty provisions of this article must be performed at no charge to the owner at a warranty station.
- (5) Notwithstanding the provisions of subsection (4) above, warranty services or repairs must be provided at distribution centers that are franchised to service the subject small off-road engine/equipment.
- (6) The small off-road engine/equipment owner must not be charged for diagnostic labor that leads to the determination that a warranted part is in fact defective, provided that such diagnostic work is performed at a warranty station.
- (7) Throughout the emissions control system's warranty period set out in subsection (b)(2), Novus or it's contracted warranty provider must maintain a supply of warranted parts sufficient to meet the expected demand for such parts and must obtain additional parts if that supply is exhausted.
- (8) Manufacturer-approved replacement parts that do not increase the exhaust or emissions of the engine or emissions control system must be used in the performance of any warranty maintenance or repairs and must be provided without charge to the owner. Such use will not reduce the warranty obligations of Novus or it's contracted warranty provider.
- (9) The use of add-on or modified parts may be grounds for disallowing a warranty claim made in accordance with this Article. Novus or it's contracted warranty provider will not be liable under this Article to warrant failures of warranted parts caused by the use of an add-on or modified part.
- (10) Novus shall provide any documents that describe that it's warranty procedures or policies within five working days of request by the Executive Officer.
- (d) A list of all emissions warranty parts must be included with each new engine or equipment subject to this Article. The emissions warranty parts list shall include all parts whose failure would increase exhaust and evaporative emissions, and contains the following parts:

EMISSIONS PARTS LIST

Exhaust Emission

- (1) Fuel Metering System
- (A) Carburetor and internal parts (and/or pressure regulator or fuel injection system).

- (B) Air/fuel ratio feedback and control system.
- (C) Cold start enrichment system.
- (2) Air Induction System
- (A) Controlled hot air intake system.
- (B) Intake manifold.
- (C) Air filter.
- (3) Ignition System
- (A) Spark Plugs.
- (B) Magneto or electronic ignition system.
- (C) Spark advance/retard system.
- (4) Exhaust Gas Recirculation (EGR) System
- (A) EGR valve body, and carburetor spacer if applicable.
- (B) EGR rate feedback and control system.
- (5) Air injection System
- (A) Air pump or pulse valve.
- (B) Valves affecting distribution of flow.
- (C) Distribution manifold.
- (6) Catalyst or Thermal Reactor System
- (A) Catalytic converter.
- (B) Thermal reactor.
- (C) Exhaust manifold.
- (7) Particulate Controls
- (A) Traps, filters, precipitators, and any other device used to capture particulate emissions.
- (B) Miscellaneous items Used in Above Systems
- (A) Vacuum, temperature, and time sensitive valves and switches.
- (B) Electronic controls.
- (C) Hoses, belts, connectors, and assemblies.

Evaporative Emission

- (1) Fuel Tank
- (2) Fuel Cap
- (3) Fuel lines(for liquid fuel and fuel vapors)
- (4) Fuel Line Fittings
- (5) Clamps
- (6) Pressure Relief Valves
- (7) Control Valves
- (8) Control Solenoids
- (9) Electronic Controls

- (10) Vacuum Control Diaphragms
- (11) Control Cables
- (12) Control Linkages
- (13) Purge Valves
- (14) Gaskets
- (15) Liquid/Vapor Separator
- (16) Carbon Canister
- (17) Canister Mounting Brackets
- (18) Carburetor Purge Port Connector

Note: As they relate to the emissions control system.

(e)Written instructions for the maintenance and use of the emissions control system by the owner shall be furnished with each new engine or equipment subject to this Article. The instructions must be consistent with this Article and applicable regulations contained herein.

(f)The documents required by subsections (d) and (e) must be submitted with the application for emissions control system certification for approval by the Executive Officer. Approval by the Executive Officer of the documents required by subsections (d) and (e) is a condition of certification. The Executive Officer will approve or disapprove the documents required by subsections (d) and (e) within 90 days of the date such documents are received.

(g)The application for emissions control system certification must also include a statement regarding the maintenance of the emissions control system. The statement must include, but not be limited to, information on emissions control system maintenance, and a maintenance schedule.

(h)Any other warranty statements applicable to engines or equipment units must not imply a limitation on the emissions warranty period or its applicability to subsequent owners after the ultimate purchaser. If the warranty period for any warranty other than the emissions warranty is less than two years, the statement of such warranty must specifically state that it does not limit the emissions warranty period of two years from purchase. If any warranty other than the emissions warranty does not extend to subsequent owners after the ultimate purchaser, the statement of such warranty must specifically state that it does not affect the applicability of the emissions warranty to subsequent owners after the ultimate purchaser.